

Neo

170 x 70 x 55

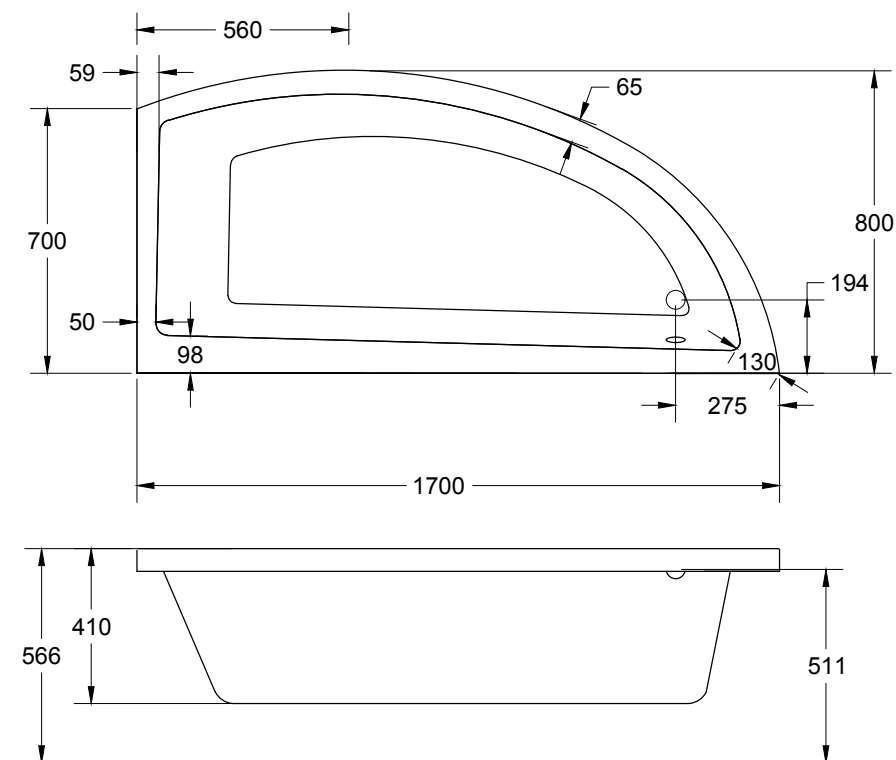

Voltaggio Voltage	220 Volt
Tension Tension	50 Hz
Potenza motore IDROMASSAGGIO WHIRPOOL motor power	0,8 hp (Standard) 1,00 hp (4 mini-jet)
Potenza assorbita IDROMASSAGGIO WHIRPOOL absorbed power	810 Watt (Standard) 930 Watt (4 mini-jet)
Potenza motore AIRPOL AIRPOL motor power	0,9 hp
Potenza assorbita AIRPOOL AIRPOOL absorbed power	700 Watt
Stabilizzazione temperatura Temperature stabilize	1300 Watt



Jets Idromassaggio Whirlpool Jets	Jets airpool	Contenuto Acqua ⁽¹⁾ Water Content ⁽¹⁾ lt	Volume di spedizione Delivery Volume m ³
6	12	210 l	1

I dati e le caratteristiche indicate non impegnano la Ditta, che si riserva il diritto di apportare tutte le modifiche ritenute opportune senza obbligo di preavviso o sostituzione.
Data and specifications given are not binding. Ditta reserves the right to make changes deemed appropriate without prior notice or obligation to update.

Neo

170 x 70 x 55

Installazione idraulica - Installazione elettrica

Hydraulic Installation - Electrical Installation

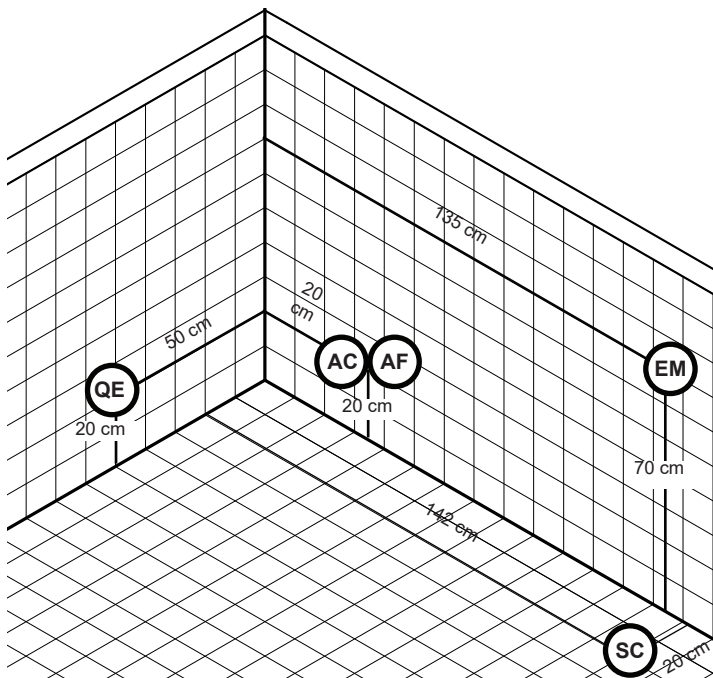

Installazione sinistra

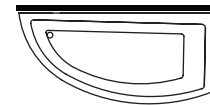
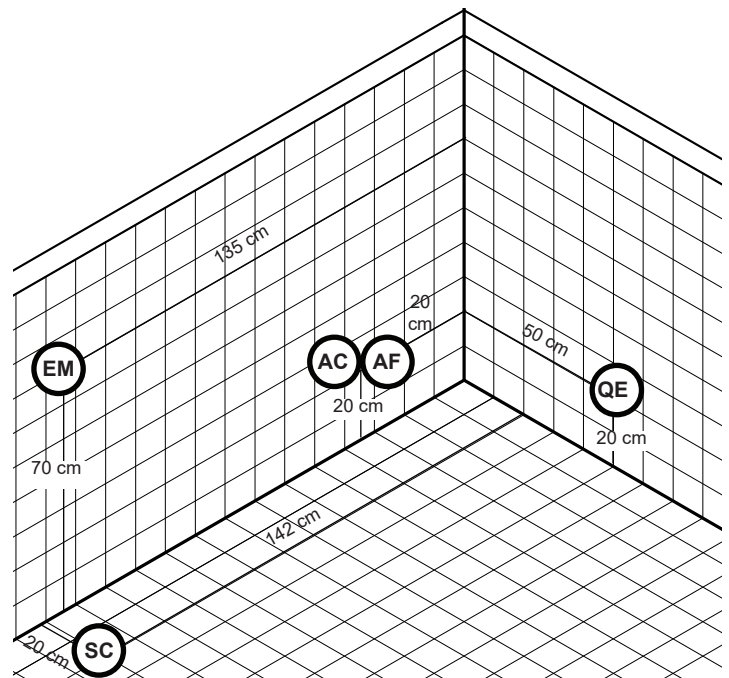

Installazione destra

A monte dell'impianto idraulico si consiglia di installare dei rubinetti filtro.
L'Azienda declina problemi derivanti dalla mancata installazione dei suddetti

Allaccio acqua calda nel caso di vasca provvista di rubinetteria

Allaccio acqua fredda nel caso di vasca provvista di rubinetteria

Scarico a terra consigliato

Allaccio alimentazione elettrica sezione minima del cavo 3 x 2,5 mmq lunghezza ml 2 circa
Predisporre l'allaccio elettrico QE solo quando necessario.

Allaccio rubinetteria muro



Hot water connection should the bathtub be fitted with taps

Cold water connection should the bathtub be fitted with taps

Recommended grounded drain

Electrical connection with minimum cable section of 3 x 2,5 mmq,

Connections for wall mounted taps